

# LIEBHERR

## Use and Care Manual

For "NoFrost" combined  
refrigerator-freezers and IceMaker

## Manuel d'utilisation et d'entretien

Pour les  
réfrigérateurs-congérateurs  
NoFrost avec IceMaker

Page 23

## Instrucciones de manejo y de mantenimiento

para combinados  
frigorífico-congelador  
NoFrost con IceMaker

Página 45

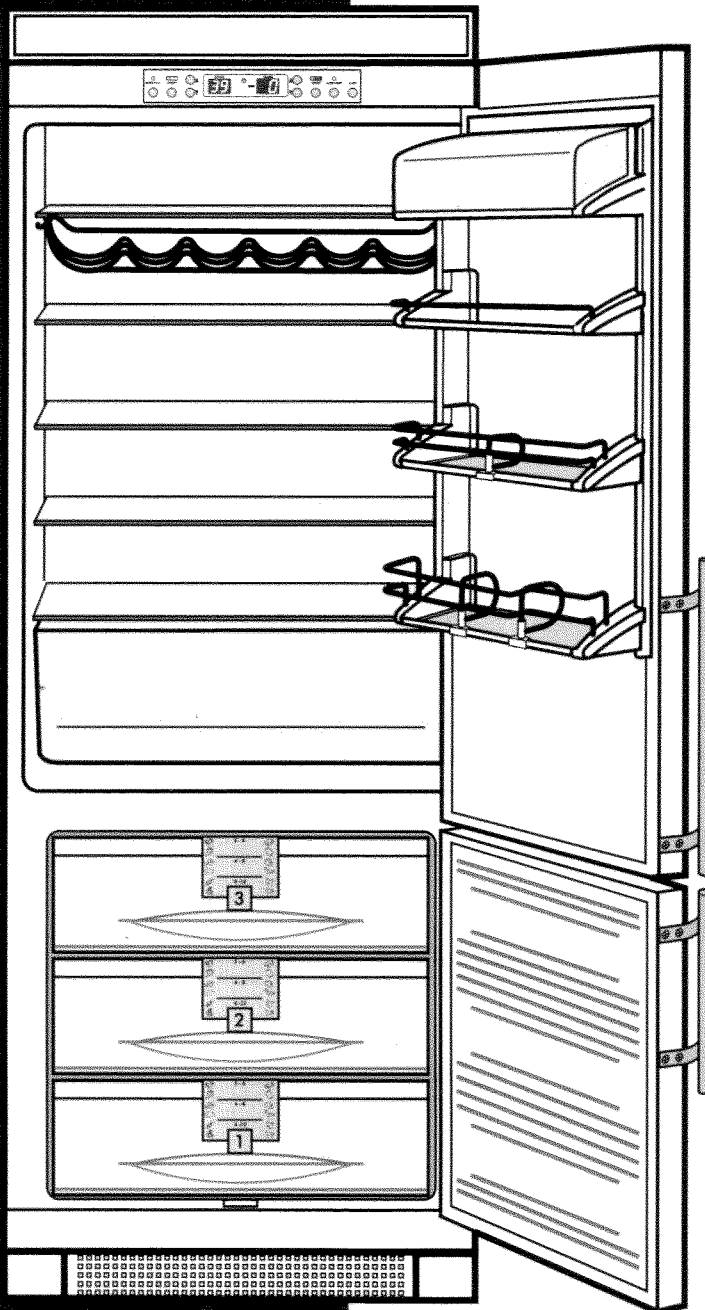

C 16

CI 16

CS 16

7080 361-03

---

Congratulations on your purchase. Choosing this appliance means you want all the benefits of state-of-the-art refrigeration technology, guaranteeing you top quality, a long appliance life span and excellent reliability.

The features on your appliance have been designed to ensure maximum convenience - day in, day out.

This appliance has been manufactured with recyclable materials using an environmentally friendly process, so together we're making an active contribution to the preservation of our environment.

To get to know all the benefits of your new appliance, please read the information contained in these operating instructions carefully.

We know you will be pleased with your new appliance.

### **Additional benefits**

- CFC-free
- Energy-optimized refrigerant circuit
- Energy-efficient insulation
- Low energy consumption
  
- User-friendly electronic controls
- Display of functions switched on
- Temperature can be controlled within climate rating range, regardless of room temperature
- Refrigerator and freezer compartments defrost automatically - no need to spend time defrosting
  
- Big net refrigerator capacity
- Variable and practical features
- Safety-glass storage shelves
- Big net freezer capacity
- Shelves can be removed to make space for large items
  
- Freezer temperature increase alarm
- Audible door open alarm
- Power failure/"frost-control" display
- Fresh food can be fast-frozen as required
- All drawers suitable for fast freezing
- Transport grips on all extra-large drawers
  
- Integrated transport grips on appliance housing
- Transport castors at back
  
- Easy to clean
- Door hinges can be changed over

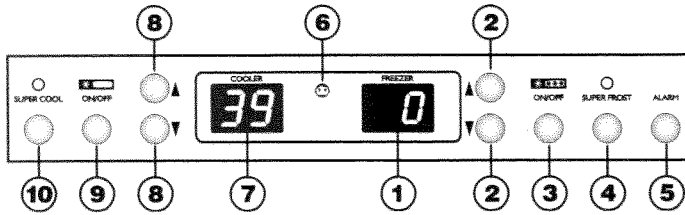

Figure 1a

## Operating and Control Elements - Figure 1a

### Freezer

- (1) Temperature Display and Setting Display
- (2) Temperature Buttons  
UP = higher, DOWN = lower
- (3) Freezer ON/OFF Button
- (4) Superfrost Button: Lit = Function Activated
- (5) Alarm Button

### Refrigerator

- (6) Childproof Lock (refrigerator and freezer display)
- (7) Temperature Display and Setting Display
- (8) Temperature Buttons  
UP = higher, DOWN = lower
- (9) Refrigerator ON/OFF Button (freezer remains ON)
- (10) Supercooling Button

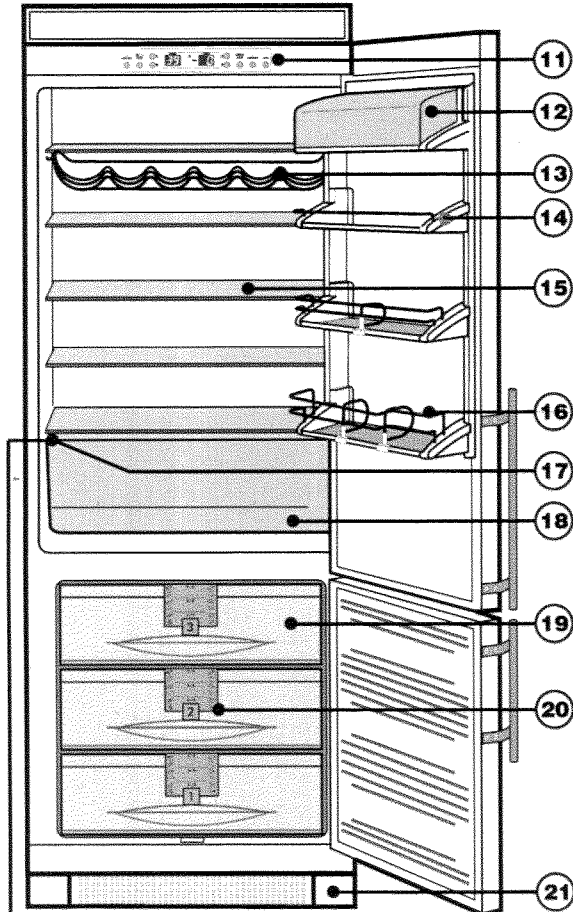

Figure 1b

## Description of Refrigerator - Figure 1b

- (11) Operating and Control Elements
- (12) Butter and Cheese Compartment
- (13) Beverage Rack
- (14) Adjustable Door Racks
- (15) Adjustable Shelves
- (16) Gallon Shelf
- (17) Model Plate
- (18) Vegetable Bin

## Description of Freezer - Figure 1b

- (19) Drawers
- (20) Freezing Chart
- (21) Adjustable-Height Unit

## Model Plate - Figure 1c

- (22) Type Designation
- (23) Service Number
- (24) Appliance / serial number
- (25) Freezing Capacity in 24 Hours

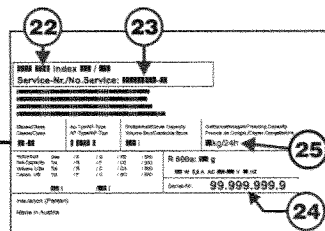

Figure 1c

# IMPORTANT

---

## **PLEASE READ AND FOLLOW THESE INSTRUCTIONS**

These instructions contain Warning and Caution statements. This information is important for safe and efficient installation and operation.

Always read and follow all Warning and Caution statements!



**DANGER**

Danger indicates a hazard which will cause serious injury or death if precautions are not followed.



**WARNING**

Warning indicates a potentially hazardous situation which, if not avoided, could result in death or serious injury.



**CAUTION**

Caution indicates a potentially hazardous situation which, if not avoided, may result in minor or moderate injury.

### ***IMPORTANT***

This highlights information that is especially relevant to a problem-free installation and operation.

Make sure incoming voltage is the same as the appliance rating.

To reduce the risk of fire, electric shock, or personal injury, installation work and electrical wiring must be done by a qualified electrician in accordance with all applicable codes and standards, including fire-rated construction.

# TABLE OF CONTENTS

Contents	Page
Safety .....	6
Disposal of Old Appliance .....	6
Important Safety Information .....	6
Electrical Safety .....	7
IceMaker (if equipped) .....	7
Safety Instructions and Warnings .....	7
Unpacking .....	8
Disposal of Carton .....	8
Safety Regulations .....	8
Operation .....	9
Turning the Appliance ON and OFF .....	9
Changing the Temperature Display .....	9
Setting the Temperature .....	9
Childproof Lock .....	10
Temperature Display .....	10
Audible Warning Signal .....	10
Power Failure/Frost-Control Display .....	11
Supercooling .....	11
Sabbath Mode .....	11
Refrigerator Compartment .....	12
Arranging Food .....	12
Shelf Arrangement .....	12
Vegetable Drawer .....	13
Interior Light .....	13
Freezer Compartment .....	14
Freezing, Storage .....	14
Freezing with Superfrost .....	14
Information System .....	14
Freezing and Storage .....	15
IceMaker .....	16
Water Connection .....	16
Connection to the Water Supply .....	16
To Start the IceMaker .....	17
To Clean the IceMaker .....	17
IceMaker Troubleshooting .....	18
Defrosting/Cleaning .....	19
Defrosting .....	19
Cleaning .....	19
Vacation Tips .....	19
Troubleshooting .....	20
Customer Service .....	21
Appliance Information .....	21
Liebherr Warranty Plan .....	22

## IMPORTANT

*All types and models are subject to continuous improvement. The manufacturer reserves the right to make modifications in the shape, equipment and technology.*

# SAFETY

## Disposal of Old Appliance

Be sure to follow your local requirements for disposal of appliances. Discarded appliances can be dangerous.

### DANGER

**Risk of child entrapment. Before you discard your old refrigerator or freezer:**

- Be sure to follow your local requirements for disposal of appliances. Discarded appliances can be dangerous.
- Remove the doors.
- Leave the shelves in place so that children may not easily climb inside.
- Cut off the prongs from the power cable plug and discard them.
- Cut off the power cable from the discarded refrigerator. Discard separately from the refrigerator.

Following these instructions reduces the possibility of causing personal injury, especially to children playing.

Contact the trash collection agency in your area for additional information.

## Important Safety Information

This appliance is intended for domestic use only. Use the appliance only for its intended purpose, the storage of food products. Follow the cautions and safety warnings throughout this instruction manual including the following:

- To prevent injury to you or damage to the unit, the appliance should be unpacked and set up by two people.
- If the appliance is damaged on delivery, contact the supplier immediately before connecting to the power source.
- To guarantee safe operation, ensure that appliance is set up and connected as described in these operating instructions.
- Disconnect the appliance from the power source if a fault occurs. Pull out the plug, turn off or remove the fuse.
- When disconnecting the appliance, use the plug. Do not pull on the cable.
- Any repairs and work on the appliance should only be carried out by the customer service department. Unauthorized work may be dangerous to the user. Changing the power source cable should only be done by the customer service department.
- Do not eat ice cream, particularly ice cream treats, or ice cubes, immediately from the freezer compartment. There is a risk of "burning" because of the very cold temperatures.
- Do not consume food which has been stored for too long; it could cause food poisoning.
- The appliance is designed for cooling, freezing and storage of food, and for making ice. It is intended for domestic use.
- Do not store explosives or sprays using combustible propellants such as butane, propane, pentane, etc. in the appliance. Electrical components might cause leaking gas to ignite. You may identify such sprays by the printed contents or a flame symbol.
- Do not use electrical appliances inside the appliance.
- Do not allow children to play with the appliance. Children must not climb, sit or stand on the shelves, drawers or door.
- To prevent possible injury due to an electrical shock, be sure to disconnect the power cord or turn off the circuit breaker before replacing the interior light or cleaning the appliance.
- To prevent possible injury due to broken glass, use hand protection when replacing the interior light.
- To avoid injury or damage to the appliance, do not use steam cleaning equipment to clean the appliance.
- Do not operate the refrigerator in the presence of explosive fumes.
- In the event of a power outage, minimize opening the refrigerator door(s). Protect the food either by placing dry ice on top of the packages or using a local frozen food locker if the power failure is of a long duration. Do not attempt to re-freeze any thawed previously frozen food.
- To avoid possible injury, only adjust an empty shelf. Do not attempt to adjust a shelf with food on it.

- To protect the refrigerator from possible damage, allow the appliance to stand 1/2 to 1 hour in place before turning the electricity on. This allows the refrigerant and system lubrication to reach equilibrium.

## Electrical Safety

Connect this appliance to a 110-120 VAC, 15 amp (20 Amp for side-by-side installations) circuit that is controlled by a circuit breaker or fuse. This appliance should have its own separate grounded circuit. Do not use an extension cord.

The power cord is equipped with a three-prong (grounding) plug for your protection against possible shock hazards. To maintain this protection:

- Do not modify the plug by removing the round grounding prong.
- Do not use a two-prong adapter. Where a two-prong wall receptacle is encountered, contact a qualified electrician and have it replaced with a three-prong receptacle in accordance with all local codes and ordinances.
- Do not use a power cord that is frayed or damaged.

## IceMaker (if equipped)

The icemaker for a combined refrigerator-freezer is located in the freezer compartment. It must be connected to the water supply to function properly. These instructions only refer to the installation and operation of the icemaker. Please refer to the Use and Care Manual provided with the appliance for other installation and operation instructions. The combined refrigerator-freezer must be level for the icemaker to function properly.

## Safety Instructions and Warnings

- Do not make the water connection while the combined refrigerator-freezer is connected to an electrical outlet.
- The connection to the water supply may only be made by a trained and licensed plumber.
- The water quality must comply with the drinking water regulations for the geographical area where the appliance is located.
- The icemaker is designed exclusively to make ice cubes in quantities needed by a household and may only be operated with water appropriate for this purpose.
- All repairs and work on the icemaker may only be done by customer service personnel or other trained personnel.
- **Do not consume or use the first three batches of ice. This applies both to using the appliance for the first time and also using it after it has not been used for a long period of time.**
- **The manufacturer cannot accept liability for damage caused by equipment or water lines between the solenoid valve and the water supply.**

# UNPACKING

## ⚠ CAUTION

To avoid risk of personal injury or property damage, have two people unpack and move this appliance into place.

## ⚠ CAUTION

Protect the finished floor surface before you uncrate the unit.

Avoid placing the appliance in direct sunlight or near the stove, range top, radiators and similar heat sources. DO NOT place microwave ovens, toaster ovens or other heat-emitting appliances on top of this unit.

The floor under the appliance should be flat and level.

Keep the appliance out of the weather. The ventilation grilles should not be obstructed. Always ensure there is good ventilation all around the appliance.

As soon as you uncrate the unit:

- Examine the unit and packaging for shipping damage. Contact the carrier immediately if you suspect there is any damage.
- Note the type (model number), index, serial number, date of purchase and where purchased on the spaces provided in the back of this manual.

## Disposal of Carton

The packaging is designed to protect the appliance and individual components during moving and is made of recyclable materials.

- Corrugated board/board
- Molded polystyrene (foamed, CFC-free polystyrene)
- Polythene bags and sheets
- Polypropylene straps

## ⚠ WARNING

Keep packaging materials away from children. Polythene sheets and bags can cause suffocation!

- Please take the packaging material to your local recycling facility.

## IMPORTANT

*CI 16 - the screw covers are taped to the unit doors during shipping. Use care when removing covers. If the hinges and door handles are reversed, you must obtain the Reverse Set. Contact your Liebherr retailer. The Reverse Set is not included with the unit. The door handles must be installed before the screw covers are installed. If you fail to install the handles before the screw covers, you can damage the covers.*

## Safety Regulations

The appliance complies with UL 250 / CSA C22.2 #63 and is designed to cool, freeze and store food and to make ice (if equipped). It is designed as a household appliance.

The appliance is set to operate within specific ambient temperature limits according to its climate rating. These temperature limits should not be exceeded. The correct climate rating for your appliance is indicated on the model plate.

This is explained as follows:

Climate Rating	Set for Ambient Temperatures of
SN	50°F to 90°F (10°C to 32°C)
SN-T	50°F to 109°F (10°C to 43°C)
N	61°F to 90°F (16°C to 32°C)
ST	61°F to 100°F (16°C to 38°C)
T	61°F to 109°F (16°C to 43°C)

- The refrigerant circuit has been tested for leaks.
- The appliance complies with current safety regulations UL250 and CSA C22.2 #63.

We recommend cleaning the appliance before turning it ON for the first time. See **Cleaning**. Turn ON the appliance several hours before loading it with frozen food for the first time. Do not load with frozen food until the temperature shows approximately 0°F (-18°C).

## ⚠ WARNING

Do not allow children to play with the appliance. Children must not climb, sit or stand on the shelves, drawers or door.



## Turning the Appliance ON and OFF - Figure 2

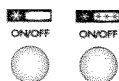

Clean the appliance before turning it on for the first time. See **Cleaning**.

Allow the appliance to operate approximately two hours before placing food in it. **DO NOT** place frozen food in the freezer until the temperature shows at least 0°F / -18°C. The refrigerator and freezer compartments can be operated separately.

- Turning ON:** Press the Refrigerator ON/OFF button ⑨ and the Freezer ON/OFF button ③ so the Temperature Displays ① and ⑦ light up or "flash."

  - The interior light will turn ON when the refrigerator door is open.
  - The alarm will sound when the freezer is turned ON for the first time and when the appliance is "warm."

- Press the Alarm button ⑤ to turn it OFF. See **Audible Warning Signal**.
- Turning OFF:** Press the Refrigerator ON/OFF button ⑨ and the Freezer ON/OFF button ③ again so the temperature displays go out.

## Changing the Temperature Display - Figure 2

The temperature reading can be displayed in either degrees Fahrenheit or degrees Celsius.

When the appliance is first turned on or after a power failure, the refrigerator Temperature Display and Setting Display ⑦ will show the set temperature display, either degrees Fahrenheit or degrees Celsius, for five seconds. Then, the actual temperature is displayed.

### To change the temperature display:

- Press both the Alarm button ⑤ and the DOWN Refrigerator Temperature button ⑧ for seven seconds. The set temperature display will blink six times.
- While the temperature display is blinking, press both buttons again and the temperature display will change.
- After making the change, the new temperature display will blink six times. Then both temperature displays will show the actual temperature value.

## Setting the Temperature - Figure 2

The appliance is pre-set for normal operation. We recommend temperatures of 39°F (4°C) in the refrigerator and 0°F (-18°C) in the freezer.

### To reduce the temperature:

- Press the DOWN button on the left to reduce the refrigerator temperature ⑧ and the DOWN button on the right to reduce the freezer temperature ②.

### To increase the temperature:

- Press the UP button on the left to increase the refrigerator temperature ⑧ and on the right to increase the freezer temperature ②.
- While you are entering the temperature, **the set temperature will flash** on the display.
  - When you press the temperature setting buttons for the first time, the most recent setting (known as the "reference setting") is displayed.
  - You can change the settings in increments of 1°F (1°C) by briefly pressing the buttons again. If the buttons are held down the temperature setting will change faster.
  - Approximately five seconds after the button has been released, the display will automatically show the actual freezing or cooling temperature (known as the "actual setting").
  - You can change the temperatures:
    - In the refrigerator** – between 36°F and 44°F (2°C and 7°C) and
    - In the freezer** – between -15°F and 6°F (-26°C and -14°C).

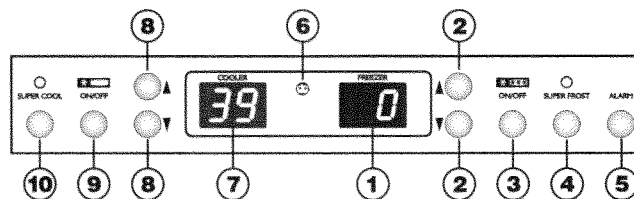



Figure 2

# OPERATION



## Childproof Lock - Figure 3

 The childproof lock is designed to protect the appliance from being turned OFF accidentally.

- Turning ON:** Hold down the Alarm button ⑤ and then press the Superfrost button ④. Keep both buttons pressed simultaneously for approximately three seconds.
  - A double beep confirms your entry.
  - The Childproof Lock Display ⑥ will come ON.
- Turning OFF:** Press this key combination again; the display ⑥ will now turn off.

## Temperature Display - Figure 3

In normal operation, the following settings will be displayed:

-  • the average refrigerator temperature in display ⑦
-  • the warmest frozen food temperature in display ①.

When starting up for the first time or when the appliance is warm, dashes will appear until the temperature reaches a level that can be displayed; 32°F to 66°F (0°C to 19°C) in the refrigerator and below 32°F (0°C) in the freezer.

It will take between three and eight hours for the required temperature, 0°F or 39°F (-18°C or 4°C) to be reached and displayed permanently in the display, depending on the ambient conditions and the temperature setting.

### The display will flash:

- if you change the temperature or
- if the temperature rises by several degrees, indicating cold loss, e.g. if you place fresh, "warm" food in the freezer or if you remove or repack frozen food, the temperature may rise for a short time due to warm air flowing into the freezer.
- If "F1" to "F5" appears in the display, the appliance has a fault. Have the fault number available when you contact the customer service department.

## Audible alarm signal - Figure 3

The audible alarm signal helps to protect frozen food and to save energy.

 **The audible alarm signal is switched off** by pressing the alarm button ⑤. It switches off automatically as soon as the temperature is low enough or the door is closed.

### Audible door alarm

This sounds when the door has been left open for longer than about 180 seconds. The sound switch-off function is active as long as the door is left open. The alarm automatically switches back to standby when the door is shut.

### Audible/visual temperature alarm

It always sounds if the refrigerator temperature is too high or too low or the freezer temperature is not low enough. The *temperature display flashes* at the same time.

This can be caused by:

- warm, fresh food being placed in the freezer;
- too much warm air from the outside entering when re-arranging or removing frozen food.

The temperature display will continue to *flash* until the cause of the alarm has been rectified. It will then stop flashing and light up continually. The audible warning signal is now automatically *reset*.

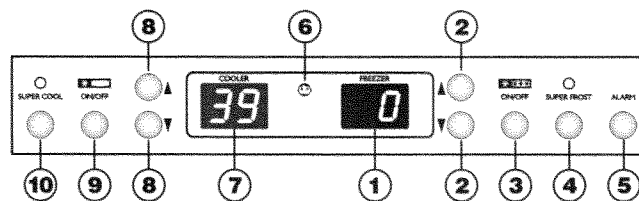

Figure 3

## Power Failure/Frost-Control

### Display - Figure 3

If **nR** appears in the display, this means the freezer temperature has risen too **high** during the last few hours or days due to a power failure.

- If you press the Alarm button ⑤ while the display is reading, the highest temperature registered during the power failure will be displayed.
- Check the quality of the food in case it has become too warm or even defrosted.
- The highest temperature will appear for approximately one minute. After that, the actual temperature in the freezer will reappear. The display can be turned OFF by repeatedly pressing the Alarm button.

## Supercooling - Figure 3

 The Supercooling button switches the refrigerator compartment to maximum cooling. It is recommended particularly if you wish to cool large quantities of food, drinks, freshly baked goods or meals rapidly.

- **Turning ON:** Press the Supercooling button ⑩ briefly so the LED turns on. The refrigerator temperature will drop to its lowest value.

### IMPORTANT

*The Supercooling function uses slightly more energy. After approximately six hours, however, the refrigerator switches back automatically to normal energy-saving operation. If required, the Supercooling function can be turned OFF sooner.*

- **Turning OFF:** Press the Supercooling button again until the LED turns off.

## Sabbath Mode

This feature considers the Religious requirements on Sabbath or Holidays. When the Sabbath Mode is active some functions of the electronic controls are switched off.

### The door can be opened and closed at any time.

- The lighting remains off.
- The cooling fan remains in its actual state: If it is on it remains on, if it is off it remains off.
- There is no door alarm.

### Further on:

- There is no temperature alarm
- Defrost cycles are independent of the number of times and length of door openings.
- The unit will return into Sabbath Mode after a power failure.

### How to activate the Sabbath Mode:

- Switch off the Ice Maker by pressing the On/Off-button on the IceMaker (Fig. 4). The IceMaker is in the top left drawer in the freezer compartment. You can identify this drawer by its labeling "IceMaker."

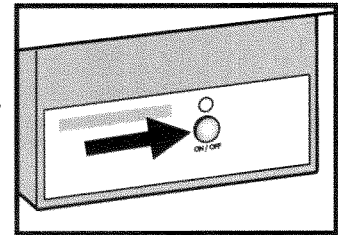

Figure 4

- Press the buttons "Alarm" ⑤ and "Temperature up" ⑧ simultaneously for 3 seconds. The display then shows "On" . (Fig. 3)

### How to deactivate the Sabbath Mode:

- Press the buttons "Alarm" ⑤ and "Temperature up" ⑧ simultaneously for 3 seconds. (Fig. 3) The display then shows the actual temperature of the refrigerator and of the freezer compartment.
- Switch on the IceMaker by pressing the On/Off-button on the IceMaker in the freezer compartment. (Fig. 4)

# REFRIGERATOR COMPARTMENT

## Arranging Food - Figure 5

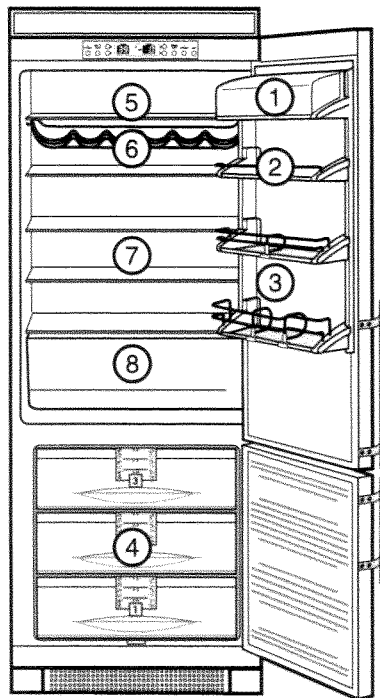

Figure 5

- (1) Butter, cheese
- (2) Eggs
- (3) Gallon containers, cans, drinks, bottles
- (4) Frozen food, ice cubes
- (5) Cans, drinks, bottles
- (6) Meat and sausage products, dairy products
- (7) Baked goods, pre-cooked meals
- (8) Fruit, vegetables, salad

### IMPORTANT

- Liquids and food which give off or absorb odors and flavors should always be stored covered or in closed containers.
- High-percentage alcohols should be tightly sealed and stored upright.
- Fruit, vegetables and salad can be stored unpacked in the bins.

## Shelf Arrangement



To avoid possible injury, only adjust an empty shelf. Do not attempt to adjust a shelf with food on it.

You can rearrange the height of the shelves and door racks as required.

### IMPORTANT

The beverage rack can be installed anywhere except on the bottom. The bottom glass shelf is shorter than the other shelves so the door can close when the gallon shelf on the door is used. DO NOT use any other shelf on the bottom. The beverage rack sits on the glass shelf supports.

## Repositioning the door racks - Figure 6

Slide the door rack up, pull-out toward you and replace in reverse order.

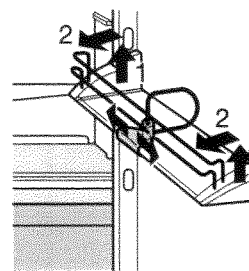

Figure 6

## Adjusting the bottle holder

You can protect the bottles from falling over when the door is opened and closed. Always hold by the plastic handle.

## Repositioning the shelves - Figure 7

Lift the shelf, slide forward and remove. Always insert shelves with the raised edge at the back pointing up, otherwise food may freeze onto the rear wall.

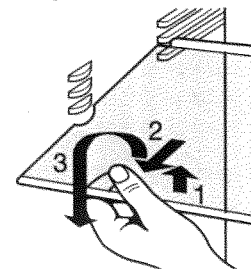

Figure 7

## If you need space for large bottles and containers - Figure 8

Lift the front half of the split glass shelf and carefully slide it under the back half until the stops click into the recesses.

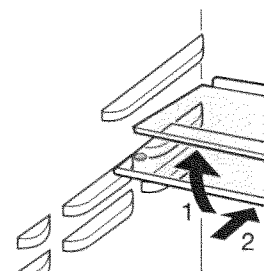

Figure 8

# REFRIGERATOR COMPARTMENT

## Vegetable Drawer - Figure 9

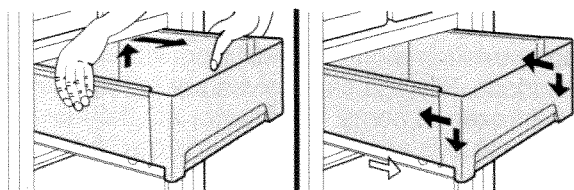

Figure 9

### To remove the vegetable drawer:

Pull the drawer straight out, grip at the back and lift out.

### To install the vegetable drawer:

Place the drawer on the rails. The rails must be fully extended and aligned with the front of the drawer. Slide the drawer in.

## Interior Light

This turns OFF automatically after the door has been opened for approximately 15 minutes. If it does not turn ON when the door is opened briefly, but the temperature display is working, the bulb(s) may be defective.

The light is located behind the cover located at the top of the refrigerator compartment and has two bulbs.

### Bulb data:

120 V, Maximum wattage - 25 W

Bulb fitting - E14

Current and voltage must agree with details on the model plate.

## Replacing the bulb:

### ⚠ WARNING



To prevent possible injury due to an electrical shock, be sure to disconnect the power cord or turn OFF the circuit breaker before replacing the interior light bulb(s) or cleaning the appliance.

### ⚠ CAUTION

To prevent possible injury due to broken glass, use hand protection when replacing the interior light bulb(s).

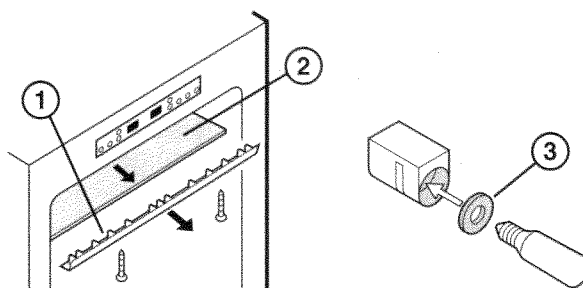

Figure 10

1. Remove the two screws securing the cover (**Fig. 10, ①**). Pull the cover straight out.
2. Remove the glass plate (**Fig. 10, ②**).
3. Remove the defective bulb. Make sure the seal (**Fig. 10, ③**) is placed on the new bulb before installing it.
4. Install the glass plate and cover.

# FREEZER COMPARTMENT

## Freezing, Storage - Figure 11

Fresh food should be frozen completely and as rapidly as possible. Frozen food can also be given a cold boost. This is provided by the Superfrost feature and ensures that the nutritional value, appearance and flavor of the food remain intact.

- The maximum amount of food which can be frozen in 24 hours is shown on the model plate ("Freezing capacity ... kg/24h"), ②. This amount varies according to the model and climate rating.

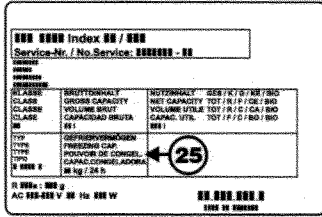

Figure 11

## Freezing with Superfrost - Figure 12

- Press the Superfrost button ④ briefly so the LED turns ON. The freezer temperature will decrease and the appliance will change to the lowest temperature.

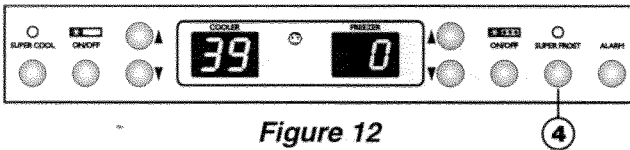

Figure 12

- For small amounts of frozen food, it is normally sufficient to turn ON Superfrost six hours beforehand. For the **maximum** amount (see freezing capacity on the model plate) you will need to turn it ON 24 hours before.
- Then place the fresh food inside the freezer, preferably in the top drawer. If freezing the maximum quantity of food, DO NOT use the drawers; instead, place the wrapped food directly on the glass shelves. Once the food is frozen, you can place it into the drawers.
- The Superfrost function turns OFF automatically. Depending on the quantity of food placed in the freezer, this will normally be between 30 and maximum of 60 hours. The freezing process is now complete; the Superfrost LED will turn OFF, and the freezer will change back to normal energy-saving operation.

### IMPORTANT

You should not turn ON the Superfrost function:

- when placing frozen food in the freezer;
- when freezing up to approximately 4-1/2 lbs (2 kg) fresh food daily.

## Information System - Figure 13

Use frozen food within the recommended period. The numbers between the symbols indicate the storage period in months for different kinds of frozen foods. Storage times given are guidelines for food frozen at home. Whether or not the lower or upper value is applicable depends on the food quality and how it was processed prior to freezing. The lower values always apply to food with a high fat content.

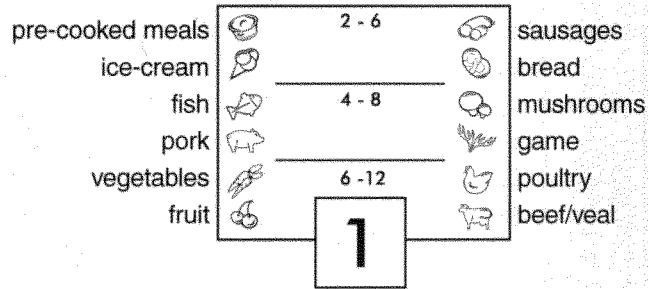

Figure 13

# FREEZER COMPARTMENT

## Freezing and Storage

### Do Not Freeze:

Lettuce, radishes, grapes, whole apples, pears, and fatty meat.

### Food to Freeze:

Meat, game, poultry, fresh fish, vegetables, fruit, dairy products, bread, baked goods, pre-cooked meals.

- Pack frozen food in standard freezer bags or reusable plastic, metal or aluminum containers.
- Do not allow fresh food which is to be frozen to come into contact with food already frozen. Always keep packages dry in order to avoid them sticking together.
- Always write the date and contents on the package and do not exceed the stated storage time for the food. This prevents spoiling.
- Pack food which you are freezing yourself in quantities right for your household. To ensure the food freezes right through quickly, the following quantities should not be exceeded per package:
  - fruit, vegetables: up to 2-1/4 lbs (1 kg);
  - meat: up to 5-1/2 lbs (2.5 kg).
- Blanch **vegetables** after washing and cutting them. (Add to boiling water for 2-3 minutes, remove and quickly cool down in cold water. If you blanch with a steamer or microwave oven, please follow the operating instructions.)
- Do not salt or season fresh food or blanched vegetables before freezing. Only lightly salt and season other food. Some spices can alter their flavor intensity.
- Do not freeze bottles and cans which contain carbonated drinks as they might burst. Drinks can be cooled down quickly, but take the bottles out of the freezer compartment after an hour at the most.
- Only take out as much food as needed for thawing. Cook food which has been thawed as quickly as possible. Frozen food can be thawed in the following ways:
  - in a microwave oven
  - in the refrigerator: the safer way to thaw food because there is less chance of bacteria growth. Use this method for high density food such as roasts or poultry.
  - Flat portions of meat or fish can be cooked when partially thawed.
  - Vegetables can be cooked from frozen ( in half the normal time).

# ICEMAKER

## Water Connection

Please read the first three points of the safety instructions and warnings before connecting the appliance to the main water supply.

- The water pressure must be between 21.8-87.0 psi (1.5-6 bar).
- Use a 1/4" OD copper line to connect the water supply to the solenoid valve. **This is not supplied with the refrigerator (Figure 14).**
- A shut-off valve, such as the saddle valve illustration here, must be installed between the hose line and the main water supply so the water supply can be stopped if necessary.

**Do not install the shut-off valve behind the refrigeration unit.**

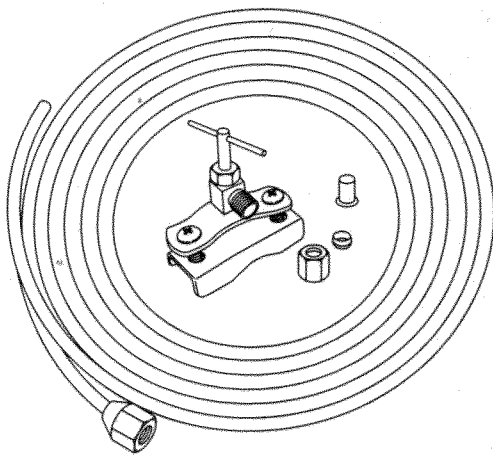

Figure 14

- If you have hard water, we recommend you install a water softener. Also, a filter must be installed if the water contains solids such as sand.
- All equipment and devices used to supply the water to the appliance must comply with the current regulations for your geographical area.

## Connection to the Water Supply

1. Install the shut-off valve, water filter and automatic shut-off device as required.

### Note

*The solenoid valve is located at the rear of your unit.*

2. The 1/4" OD copper tubing between the shut-off valve and solenoid valve has a *Metric R3/4 male connector (Figure 15)*. Make sure there is approximately 30" (70 cm) of excess tubing behind the unit for easy connection.

### Note

*A R3/4(metric) to a 1/4" OD adapter is supplied with the ice-maker.*

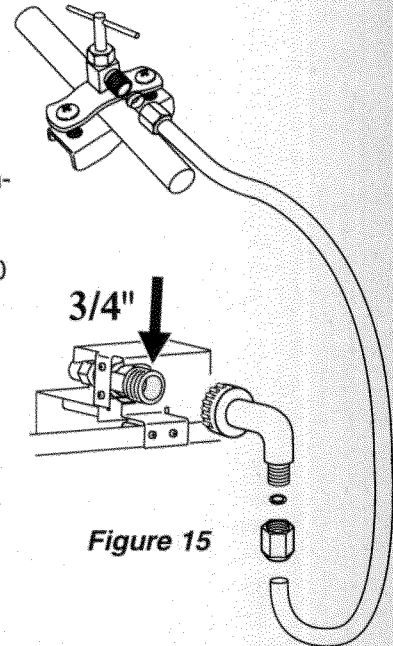

Figure 15

3. Open the shut-off valve for the water supply and check the entire water system for leaks. Before the appliance is used for the first time a licensed plumber should bleed air from the system.
4. Insert the electrical plug for the combined refrigerator/freezer into the electrical outlet (Figure 16).
5. Move the combined refrigerator-freezer into final position in the room.

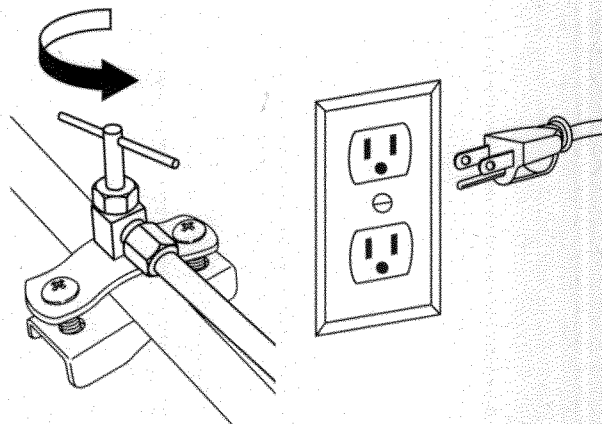

Figure 16



## To Start the IceMaker

The IceMaker will only work if the combined refrigerator-freezer is connected to the electrical outlet. It will only make ice cubes if the freezer compartment is operating.

The IceMaker is in the top left drawer in the freezer compartment of the combined refrigerator-freezer. You can identify this drawer by its labeling "IceMaker."

### To turn on

- Pull out the drawer.
- Press the "ON/OFF" button so the control lamp comes on (**Figure 17**).
- Close the drawer.

#### Note

*The icemaker can only make ice cubes if the drawer is completely closed.*

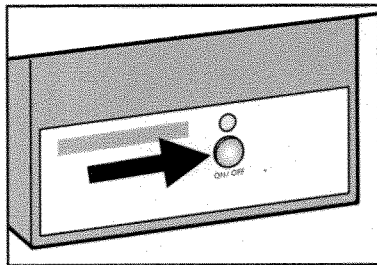

**Figure 17**

### To turn off

If you do not need any ice cubes, the icemaker can be turned off independently of the freezer compartment.

- Press the "ON/OFF" button for approximately 1 second so the control lamp goes out.

#### Note

*If the icemaker is turned off, the empty drawer can also be used to freeze and store food.*

### To make ice cubes

After you start the icemaker for the first time it may take up to 24 hours before the first ice cubes are ready.

#### Note

*The first three batches of ice must not be consumed or used.*

The production capacity depends on the temperature inside the freezer compartment. The lower the temperature, the more ice can be produced over a period of time.

The ice cubes fall out of the icemaker into the drawer. When the ice reaches a certain level in the drawer, the appliance stops producing ice automatically.

If you need a large quantity of ice you can change out the drawer to the right with the complete "IceMaker" drawer. When you close the drawer the icemaker will immediately start production.

## To Clean the IceMaker

The IceMaker (arrow in **Figure 18**) can be cleaned by using this procedure.

1. Pull out the drawer and remove the ice.
2. Clean the drawer with warm water and mild dish detergent.
3. To access the IceMaker for cleaning:
  - a. With the drawer pulled out, press and hold the "ON/OFF" button until the LED goes out (takes about 1 second).
  - b. Continue to hold the button and after 10 seconds the LED will start to flash.
  - c. Insert the drawer while the LED is flashing. The IceMaker should rotate down into the cleaning position.
  - d. Remove the drawer.
4. Clean the IceMaker with warm water. If you need to use a cleaning aid, use a mild dish detergent and rinse. **You will need to throw out the first three batches of ice if you use any soap.**
5. Push the "ON/OFF" button until the LED lights and insert the drawer.
6. **Throw out the first three batches of ice to remove any soap residue.**

#### Note

*If you need to leave the IceMaker off, clean the IceMaker but do not push the "ON/OFF" button in Step 5.*

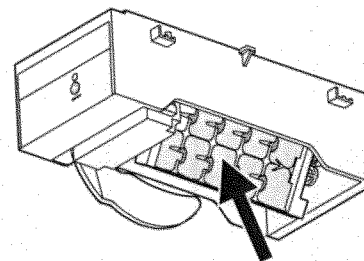

**Figure 18**

# ICEMAKER

---

## IceMaker Troubleshooting

If a problem occurs during operation, check whether it is due to an operating error. Please note that even during the warranty period, some repair costs may be your responsibility.

You may be able to correct the following faults yourself:

If you are unable to repair the fault yourself or if the control lamp above the "ON/OFF" button flashes, contact our customer service department. Refer to the "Troubleshooting" section in the operating instructions for the combined refrigerator-freezer for details on obtaining service.

Problem	Possible Cause and Remedy
Icemaker cannot be turned on.	Is the combined refrigerator-freezer connected to the electrical outlet?
Icemaker is not making any ice.	<ul style="list-style-type: none"><li>- Is the icemaker turned on?</li><li>- Is the water supply line open?</li><li>- Is the icemaker drawer closed properly?</li></ul>

# DEFROSTING/CLEANING

## Defrosting

### Refrigerator compartment:

The refrigerator compartment defrosts automatically. The water that forms on the rear wall drains into a reservoir at the back of the appliance and evaporates automatically through the compressor heat.

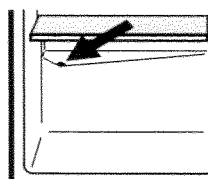

Figure 19

Ensure the defrost water can flow freely through the drain hole in the rear wall (Figure 19).

### Freezer compartment:

The No-frost system automatically defrosts the freezer compartment. Any moisture will collect on the evaporator and freeze. It will periodically defrost and evaporate.

## Cleaning

### WARNING



- To prevent possible injury due to an electrical shock, be sure to disconnect the power cord or turn OFF the circuit breaker before replacing the interior light bulb(s) or cleaning the appliance.
- To avoid injury or damage, DO NOT use steam cleaning equipment to clean the appliance.

Clean the appliance by hand with lukewarm water and a little detergent.

**DO NOT** use abrasive or scouring sponges. **DO NOT** use concentrated cleaning agents. **NEVER** use abrasive or acid cleaners or chemical solvents.

- Ensure no cleaning water penetrates into the electrical components or ventilation grille.
- Dry all parts well with a cloth.
- Remove dust from the refrigerator unit and heat exchanger and the metal grid at the back of the appliance. This should be done at least once a year.
- **DO NOT** damage or remove the model plate on the inside of the appliance. It is very important for servicing your appliance.

Keep your stainless steel looking new by cleaning with a good quality stainless steel cleaner or polish monthly. High quality stainless steel cleaners and conditioners are commercially available.

**DO NOT CLEAN WITH STEEL WOOL PADS or ABRASIVE PADS. DO NOT use cleaners that are not for use on stainless steel, such as glass, tile or counter cleaners. These types of cleaners can damage the surface permanently.**

Stainless steel that is exposed to chlorine gas and moisture may have some discoloration. This discoloration is normal. If your unit is used in this environment, clean and polish your stainless steel more often.

If the surface discolors or rusting appears, clean it quickly with a non-abrasive cloth and protect it. Always clean and polish in the direction of the grain and finish.

## Vacation Tips

### Short vacations:

It is not necessary to turn OFF the refrigerator and freezer if you will be away for less than four weeks.

- Use all perishables.
- Freeze other items.
- Turn OFF the icemaker.
- Shut off the water supply to the icemaker.

### Long vacations:

If you will be away for a month or more:

- Remove all food from the refrigerator and freezer compartments.
- Turn OFF the refrigerator and freezer compartments.
- Clean the appliance. Refer to **Cleaning**.
- Leave the door open to prevent unpleasant odors. This will also keep mold from building up.
- Turn OFF the icemaker.
- Shut off the water supply to the icemaker.

# TROUBLESHOOTING

Your appliance is designed and manufactured for a long life and reliable operation.

If a problem occurs during operation, check whether it is due to an operating error. Please note

that even during the warranty period, some repair costs may be your responsibility.

You may be able to correct the following faults by checking the possible causes yourself:

Problem	Possible Cause and Remedy
Appliance does not work, display is OFF	<ul style="list-style-type: none"><li>- Is the appliance turned ON properly?</li><li>- Is the power source plug properly inserted in the socket?</li><li>- Is the circuit breaker or fuse in operating condition?</li></ul>
The interior light does not come ON	<ul style="list-style-type: none"><li>- Is the refrigerator compartment turned ON?</li><li>- Has the door been open for more than 15 minutes?</li><li>- The bulb is defective. Change the bulb as described in <b>Interior light</b>.</li></ul>
Loud running noise	<ul style="list-style-type: none"><li>- Is the appliance standing firmly on the floor, or does the compressor cause nearby items of furniture or objects to vibrate? If necessary, move the appliance slightly, align by adjusting the adjustable feet, or move bottles and containers apart.</li></ul>
Motor seems to run too long	<ul style="list-style-type: none"><li>- Is the ambient temperature too hot? See <b>Safety Regulations</b>.</li><li>- Has the appliance been opened too often or left open too long?</li><li>- A large amount of food has been added.</li><li>- Unit is in Supercooling mode. Verify unit is in normal operation mode.</li></ul>
The temperature is not cold enough	<ul style="list-style-type: none"><li>- Is the temperature setting correct? See <b>Setting The Temperature</b>.</li><li>- Has an excessive amount of fresh food been placed in the appliance?</li><li>- Does a separately installed thermometer show the correct reading?</li><li>- Is the ventilation system working properly?</li><li>- Is the appliance set up too close to a heat source?</li></ul>
<sup>nA</sup> appears in the display	There has been a power failure; proceed as described in <b>Power Failure/Frost-Control Display</b> .

## Customer Service - Figure 20



If none of the above causes apply and you cannot correct the fault yourself, or if the temperature display reads "F1" to "F5", this means there is a fault. Please contact your nearest customer service department (see enclosed list for addresses).

Give the **fault number displayed**, together with the **Type Designation** ①, **Service Number** ② and **Appliance / serial number** ③

as given on the model plate, to ensure prompt, accurate servicing. The model plate is located inside the appliance on the left-hand side.

Leave the appliance closed until the customer service engineer arrives to prevent any further cold loss.

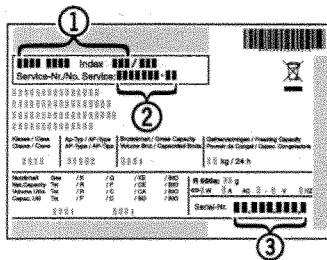

Figure 20

## Appliance Information

Record this information when the appliance is installed.

Type Designation: \_\_\_\_\_

Service Number: \_\_\_\_\_

Appliance / serial number: \_\_\_\_\_

Date of Purchase: \_\_\_\_\_

Where Purchased: \_\_\_\_\_

# WARRANTY

---

## LIEBHERR WARRANTY PLAN

**FULL TWO YEAR WARRANTY** - For two years from the date of original purchase, your Liebherr warranty covers all parts and labor to repair or replace any part of the product which proves to be defective in materials or workmanship.

**FULL FIVE YEAR WARRANTY** - For five years from the date of original purchase, your Liebherr warranty covers all parts and labor to repair or replace any components that prove to be defective in materials or workmanship in the sealed system. The "Sealed System" means only the compressor, condenser, evaporator, drier and all connecting tubing.

**LIMITED 6TH THROUGH 12TH YEAR WARRANTY** - From the 6th through 12th year from the date of original purchase, your Liebherr warranty covers all parts that prove to be defective in materials or workmanship in the Sealed System (parts only).

### TERMS APPLICABLE TO EACH WARRANTY

All service provided by Liebherr under the warranty must be performed by authorized Liebherr service representatives, unless otherwise specified by Liebherr. Service will be provided in the home during normal business hours. This warranty applies only to products installed for normal residential use. Details regarding a non-residential warranty are available on request.

The warranty applies only to products installed in Canada and any one of the fifty states of the United States or the District of Columbia. This warranty does not cover any parts or labor to correct any defect caused by negligence, accident or improper use, maintenance, installation, service or repair, including but not limited to improper removal and reinstallation of the condensing unit.

***The remedies described above for each warranty are the only ones which Liebherr will provide, either under these warranties or under any warranty arising by operation of law. Liebherr will not be responsible for any consequential or incidental damages arising from the breach of these warranties or any other warranties, whether express, implied or statutory.***

Some states do not allow the exclusion or limitation of incidental or consequential damages so the above limitation or exclusion may not apply to you. This warranty gives you specific legal rights and you may also have other rights which vary from state to state.

To receive parts and/or service and the name of the Liebherr authorized service representative nearest you, contact your Liebherr dealer or distributor or contact the Liebherr designated national service provider:

in the US: [Liebherr@adcoservice.com](mailto:Liebherr@adcoservice.com), or call 1-866-LIEBHERR or 1-866-543-2437

in Canada: [www.euro-parts.ca](http://www.euro-parts.ca), or call 1-888-LIEBHERR or 1-888-543-2437.